

Quench Protection for the MICE Cooling Channel Coupling Magnet

X. L. Guo, F. Y. Xu, L. Wang, M. A. Green *Member IEEE*, H. Pan, H. Wu, X. K. Liu,
L. X. Jia, K. Amm *Member IEEE*

Abstract—This paper describes the passive quench protection system selected for the muon ionization cooling experiment (MICE) cooling channel coupling magnet. The MICE coupling magnet will employ two methods of quench protection simultaneously. The most important method of quench protection in the coupling magnet is the subdivision of the coil. Cold diodes and resistors are put across the subdivisions to reduce both the voltage to ground and the hot-spot temperature. The second method of quench protection is quench-back from the mandrel, which speeds up the spread of the normal region within the coils. Combining quench back with coil subdivision will reduce the hot spot temperature further. This paper explores the effect on the quench process of the number of coil sub-divisions, the quench propagation velocity within the magnet, and the shunt resistance.

Index Terms—Passive quench protection, quench back, superconducting magnets, subdivision protection.

I. INTRODUCTION

THE muon ionization cooling experiment (MICE) will be a demonstration of ionization cooling in a short section of a muon cooling channel. The MICE cooling channel contains three absorber focus coil (AFC) modules and two RF coupling coil (RFCC) modules that reaccelerate the muons back to their original momentum [1]. The RFCC module consists of a 1.9 m long vacuum vessel that contains four 201.25 MHz RF cavities that are bounded by thin beryllium windows. The coupling magnet located outside of the RF cavity vacuum vessel is a superconducting solenoid that produces enough magnetic field (up to 2.2 T on axis) to guide the muons and keep them within the iris of the thin RF-cavity windows [2].

The MICE coupling solenoid uses multifilament Nb-Ti in a copper matrix. The magnet is cooled with a pair of pulse tube coolers, hence the magnet current is low. During a quench, the magnet stored energy and the high conductor current density causes a large temperature rise where the quench originated. In addition, high voltages between the coil and

ground will develop. The magnets in MICE will be passively quench-protected through coil subdivision and quench-back.

This paper describes the magnet quench protection system. The effects of coil sub-division, quench propagation velocity, and the shunt resistance across each subdivision on the magnet hot-spot temperature and the voltage to ground are studied.

II. PASSIVE QUENCH PROTECTION SYSTEM DESIGN

A. Coupling Coil Design

The coupling magnet will work in two modes due to the polarity change of two focusing coils in the AFC module. One is gradient mode (flip mode), and the other is solenoid mode (non-flip mode). Table I shows the coupling coil design parameters. The worst-case is to operate the MICE in the flip mode at a muon average momentum of 240 MeV/c. The beam beta at the center of the absorbers is designed to be 420 mm.

The coupling coils will be made from a commercial copper matrix Nb-Ti conductor originally used for MRI magnets. The conductor I_c is >760 A at 5 T and 4.2 K. Using this conductor, the magnet margin is expected to be >0.8 K when the induction at high field point is 7.4 T, the current is 210.1 A, and the cold mass temperature is 4.2 K [2].

Fig.1 shows the coupling magnet basic structure. The MICE coupling magnet consists of a single 285 mm long coil. At room temperature, the coil inner radius is 750 mm and its thickness is 102.5 mm. The coil is wound on a forged 6061-T6 aluminum mandrel. The over all design dimensions for the coil cold mass are: The inner radius is 736 mm; the thickness is 143.5 mm; and the length is 329 mm. The G-10 insulation thickness between the coil and the bobbin, the end flange and the banding are 1.0 mm, 3.0 mm and 1.0 mm respectively. The coil is indirectly cooled by liquid helium flowing in extruded cooling tubes attached to the outer surface of the coil cold mass case [3].

B. Protection Circuit Design

Fig. 2 shows the proposed coupling magnet circuit. A 300 A 10 V power supply is used charge the magnet. The magnet will be discharged through a water-cooled varistor circuit. The current into the magnet will be carried by a single pair of copper and HTS leads. The coil will have eight subdivisions with a pair of back-to-back R620 diodes at ~ 5 K and a resistor across each subdivision. The coil rapid discharge system will consist of 25 diodes mounted on a water-cooled plate. The mandrel acts as a shorted secondary circuit inductively coupled with each of the coil subdivisions [2].

Manuscript received 17 August 2008. This work was supported by the fund of cryogenics and superconductivity engineering technology innovation platform, the second phase of “985 Project” of Harbin Institute of Technology. This work was also supported by the Office of Science of the US Department of Energy under DOE contract DE-AC-02-05CH11231.

X. L. Guo, F. Y. Xu, L. Wang, H. Pan, H. Wu, X. K. Liu and L. X. Jia are with the Institute of Cryogenics and Superconductive Technology, HIT, Harbin 150001, China. M. A. Green is with Lawrence Berkeley National Laboratory, Berkeley CA 94720, USA (e-mail: magreen@lbl.gov). K. Amm is with the General Electric Research Center, Niskayuna, NY 12309, USA

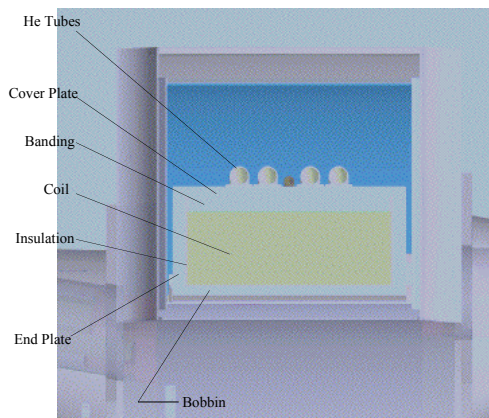

Fig. 1 Cross subdivision of the coupling magnet cryostat

TABLE I. COUPLING MAGNET SPECIFICATION

Parameter	Flip	Non-flip
Coil Length (mm)	285	
Coil Inner Radius (mm)	750	
Coil Thickness (mm)	102.5	
Number of Layers	96	
No. Turns per Layer	166	
Magnet Self Inductance (H)	592.5	
Magnet J (A mm ⁻²)*	114.6	108.1
Magnet Current (A)*	210.1	198.2
Magnet Stored Energy (MJ)*	13.1	11.6
Peak Induction in Coil (T)*	~7.40	~7.12
Coil Temperature Margin (K)*	~0.8	~1.0

*Worst case design based on $p = 240$ MeV/c and $\beta = 420$ mm

Magnet subdivision is a passive quench protection method long used in MRI magnets. Back-to-back cold diodes allow the magnet to be safely quenched at either magnet polarity. The high diode forward voltage (at least 4 V at 5 K) across the diodes prevents current from bypassing the magnet coil during a magnet charge or discharge at its design charging and discharging voltage. Magnet coil subdivision reduces both the voltage to ground and the hot spot temperature [4], [5].

The magnet aluminum mandrel is inductively coupled to all of the coil subdivisions. The mandrel will act as a shorted secondary circuit that absorbs energy from the magnet during a quench. The current in the mandrel will heat the mandrel, which will eventually heat up the adjacent coil subdivisions and induce new normal zone. This process is called quench back. Quench back will speed up the quench process, and thus reduce the hot spot temperature [6], [7].

III. THE QUENCH MODEL DESCRIPTION

A semi-empirical quench model considering both the subdivision and quench back has been developed. A quench is initiated in the mid-plane and starts to expand in the three directions with velocities v_ϕ (longitudinal propagation along the coil conductor), v_r (radial propagation) and v_z (axial

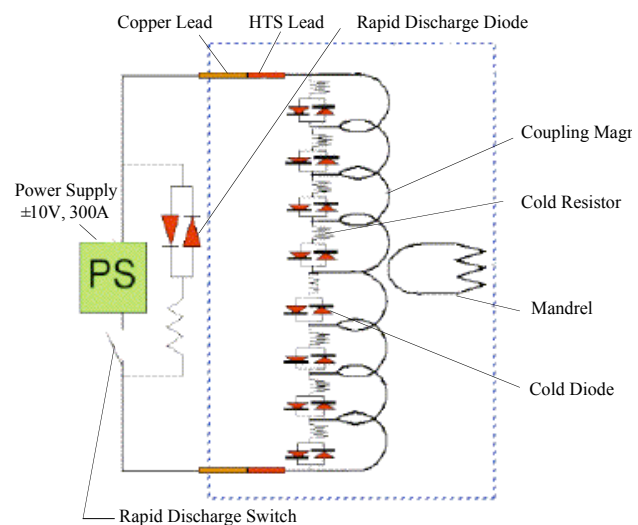

Fig. 2 Protection circuit of coupling magnet

propagation). The normal zone shape is assumed to be an ellipsoid [8]. In the model, the average constant quench propagation velocities in three directions are used during quench process. The calculation proceeds in time steps. At each step another layer is added to the surface of the normal zone like the skin of an onion. After a time step the current will have decayed. The calculation continues until each coil subdivision current is less than the 1 percent of its initial current. Helium cooling is ignored in this simulation.

Each coil section is assumed to be adiabatic, for each time step. The temperatures of each successive quenching volume are determined by the joule heating within that volume. The hot-spot temperatures are the temperatures of the start point in each subdivision. The power supply is disconnected once the quench starts. The cold diodes are assumed to be a short circuit. The rapid discharging diode stacks are assumed to be closed. The current in all conducting loops including the mandrel are calculated using the inductance matrix, the shunt resistance and the temperature-dependent normal zone resistance [9]. The voltages-to-ground are estimated by using the resistive voltage drop across the normal zone in each magnet coil subdivision.

The quench-back time is the sum of two time periods. The first time period is the time it takes for the aluminum mandrel heat up to the superconductor critical temperature (~ 9 K). This time is associated with the shift of the current from the superconducting coil to the conductive mandrel. A high resistivity mandrel will take longer to heat to 9 K than a low resistivity mandrel, hence a stainless steel mandrel is not used. The second time period in the quench back process is the time needed for heat to flow from the mandrel to the superconductor. This time is associated with the heating of the superconductor and the heating of the insulation between the superconductor and mandrel. This time is of the order of 0.08 to 0.10 s when the insulation thickness between the coil conductor and the mandrel is ~ 1 mm. [7]. After quench back occurs, the magnet normal region is the normal region due to quench propagation plus the normal region induced due to quench back from the mandrel.

IV. A PARAMETER STUDY OF THE QUENCH PROCESS

A. The Effect of Magnet Coil Subdivision

The effects of subdivision number of 2, 4, 6 and 8 were studied. All simulation cases use the quench propagation velocities shown in Table II and the shunt resistance across each subdivision is zero. Fig. 3 shows the peak hot-spot temperature as a function of the number of sub-divisions. The coil hot-spot temperature is 135 K for eight subdivisions and 149 K for two subdivisions. The peak hot-spot temperature decreases as the number of subdivisions increases. Because of inductive coupling between subdivisions, the temperature of the coil will become more uniform with more subdivisions. Fig. 4 shows the voltage to ground with different subdivision numbers. The voltage to ground is ~ 2.7 kV for 8 sub-divisions and ~ 10.6 kV for 2 sub-divisions. The maximum voltage to ground decreases as the subdivision number increases. Without subdivision the maximum coil voltage is ~ 22.5 kV. The voltage-to-ground is slightly lower without quench-back.

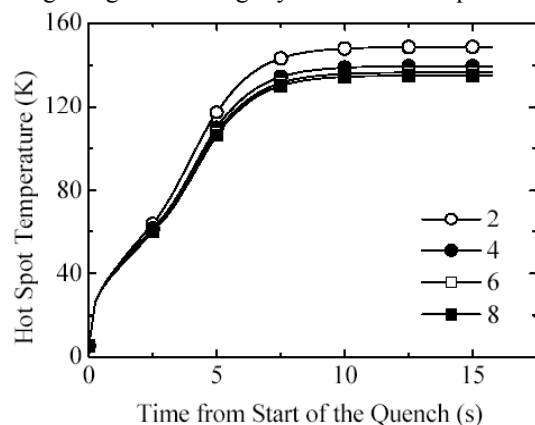

Fig. 3. Peak Hot-spot Temperature versus Time and Sub-division Number

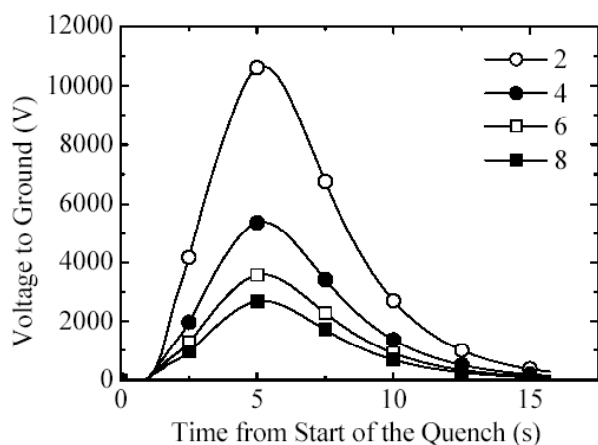

Fig. 4. Peak Voltage to Ground versus Time and Sub-division Number

B. The Effect of Quench Propagation Velocity

The effect of quench propagation velocity within the coupling magnet on the magnet quench process was studied. Table II shows two different quench velocities cases studied. The Case 1 quench velocities are based on Nb-Ti quench propagation measurements made at LBNL in the 1970's. According to this correlation, the propagation velocity is dependent only on the current density in the conductor cross-

section and the conductor magnetic induction. Both quench velocities are for an average magnet field of 2.5 T and a matrix current density of 1.4×10^8 A m⁻² [4]. Case 1 velocities correspond to using Nb-Ti in the coil. Case 2 velocities are the Case 1 velocities divided by three, which corresponds to using Nb₃Sn in the magnet. Both cases were simulated for an operating current of 210 A, an operating temperature of 4.2 K and a resistance of 0 ohms across each subdivision.

TABLE II CASES FOR QUENCH PROPAGATION VELOCITIES

	v_ϕ (m/s)	v_r (m/s)	v_z (m/s)
Case 1	3.477	0.065	0.085
Case 2	1.159	0.022	0.028

Fig. 5 shows the peak hot-spot temperature for the two cases. In Case 1 the hot-spot temperature is ~ 135 K; in Case 2 the hot-spot temperature is ~ 216 K. High quench propagation velocities make the temperature within the coil more even. Without quench-back the hot-spot temperature in the magnets would be much higher. Fig. 6 shows the voltage to ground for the quench propagation velocity cases. In Case 1 the peak voltage-to-ground is ~ 2.7 kV; in Case 2 the peak voltage-to-ground is about ~ 2.6 kV. In this model the voltage to ground is the voltage drop across the resistance of the normal zone. A fast propagation velocity induces a fast growth of normal zone resistance. With a rapid growth of normal zone resistance, the magnet current rapidly decreases. The voltage to ground is a function of both the resistance and dI/dt .

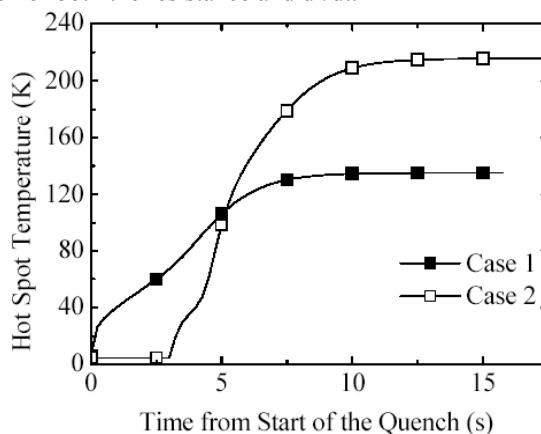

Fig. 5. Peak Hot Spot Temperature versus Time and Quench Velocities

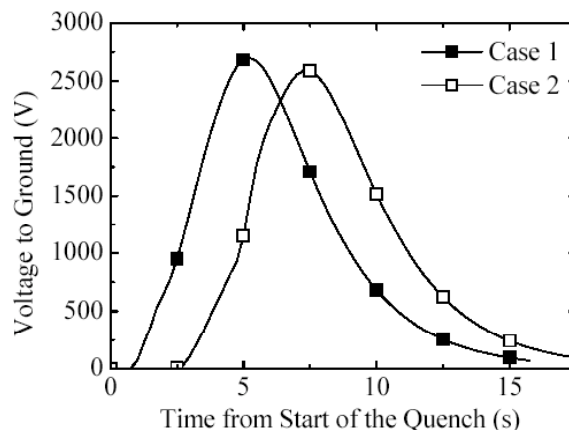

Fig. 6. Peak Voltage to Ground versus Time and Quench Velocities

C. The Effect of Shunt Resistance across a Sub-division

The effect of a resistance of 0 and 5 ohms (at 4 K) across each subdivision was studied. In both cases the voltage drops across diodes were ignored. The resistance change with temperature was also ignored. In both cases the simulations were done using the Case 1 quench propagation velocities.

Fig. 7 shows the effect of the shunt resistance on the hot spot temperature. In the 0-ohm case, the hot spot temperature is ~ 135 K. In the 5-ohm case, the hot spot temperature is ~ 100 K. The hot-spot temperature decreases with an increase in the shunt resistance. The reason for this is that the shunt resistor absorbs stored magnetic energy from the magnet. This energy doesn't end up in the coil winding. Fig. 8 shows the effect of the shunt resistance on the voltage-to-ground. In the 0-ohm case, the voltage to ground is 2.7 kV. In the 5-ohm case, the voltage to ground is 1.35 kV. The quench velocities in the two cases are same. Quench back increases the voltage-to-ground slightly for both cases.

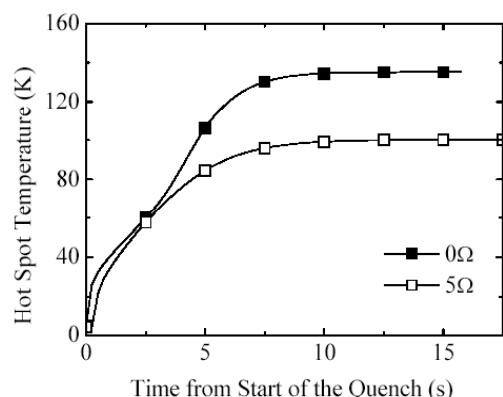

Fig. 7. Hot-spot Temperature versus Time for Two Shunt Resistances

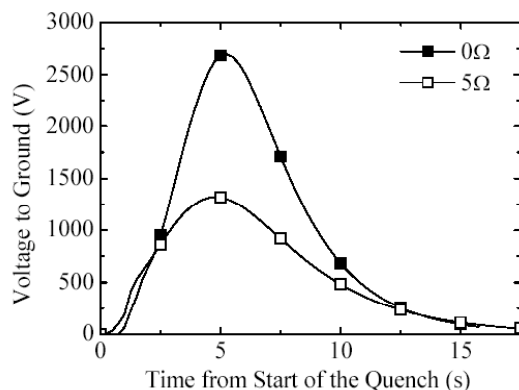

Fig. 8. Peak Voltage to Ground versus Time For Two Shunt Resistances

A large shunt resistance results in a faster current decay and a slower increase of the coil normal zone resistance. All these effects result in lower peak voltage-to-ground. When the shunt resistance per coil sub-division is 5 ohms, ~ 5.5 MJ of the coil energy ends up in the resistors. The resistors must have a mass of ~ 1.5 kg per ohm in order to absorb magnetic energy from the coil without going above 350 K. If the shunt resistance is too high, the voltage to ground and the hot spot temperature increase, because less coil energy is removed.

V. CONCLUSION

A passive quench protection system for coupling magnet based on coil subdivision and quench back has been designed. A special semi-empirical model was developed to analyze the quench process and study the effect of coil sub-division, of quench propagation velocities, and of the shunt resistance across each subdivision.

More magnet sub-divisions result in lower hot-spot temperatures and lower voltages-to-ground. Quench-back from the mandrel reduces the hot-spot temperature and increases the voltage to ground a few percent.

Faster quench propagation velocities will result in lower hot-spot temperatures, but the voltages-to-ground may increase. Quench-back will have a large effect on the hot-spot temperature when the quench propagation velocities are low. The cases illustrated were for Nb-Ti and Nb₃Sn. Hot-spot temperatures would be much higher if the coil superconductor was an HTS conductor, because HTS conductors have much lower quench propagation velocities.

A larger shunt resistance across each subdivision will result in lower hot-spot temperatures and lower peak voltages-to-ground provided significant magnetic energy is removed from the system by the shunt resistors. Since the shunt resistors are cold, they must have enough mass to keep their temperature from going above room temperature when the quench is over. In the coupling magnet, a 50 m-ohm stainless steel will be used per magnet sub-division. A larger resistor would be desirable, but the space available for the eight shunt-resistors is limited.

The MICE coupling magnet can have a passive quench protection system that is based on sub-dividing the coil and putting a cold diode and resistor across the subdivisions. Even when the resistance across the sub-division is low, eight subdivisions of the coupling magnet coil are adequate for effective quench protection of the magnet.

REFERENCES

- [1] G. Gregoire, G. Ryckewaert, L. Chevalier, et al, "MICE and International Muon Ionization Cooling Experiment Technical Reference Document", [on line] <http://www.mice.iit.edu>, 2001.
- [2] L. Wang, M. A. Green, F. Y. Xu, et al, "The Engineering Design of the 1.5m Diameter Solenoid for the MICE RFCC Modules", *IEEE Transactions on Applied Superconductivity* **18**, No. 2, p 937, 2008.
- [3] L. Wang, H. Wu, L. K. Li, M. A. Green, et al, "The Helium Cooling System and Cold Mass Support System for the MICE Coupling Solenoid", *IEEE Transactions on Applied Superconductivity* **18**, No. 2, p 941, 2008.
- [4] M. A. Green and H. Witte, "Quench Protection and Power Supply Requirements for the MICE Focusing and Coupling Magnets," MICE Note 114, <http://www.mice.iit.edu>, LBNL-57580, May 2005.
- [5] M. A. Green, L. Wang, X. L. Guo, et al "Quench Protection for the MICE Cooling Channel Coupling Magnet". LBNL-63698, MICE Note 193, <http://www.mice.iit.edu>, 31 January 2008.
- [6] M. A. Green, "Quench Back in Thin Superconducting Solenoid Magnets". *Cryogenics* **24**, p 3-10, 1984.
- [7] M. A. Green, "The Role of Quench Back in Quench Protection of a Thin Superconducting Solenoid", *Cryogenics* **24**, p 659-668, 1984.
- [8] M. N. Wilson, *Superconducting Magnets*, Oxford University Press, Oxford, 1983. p 209-219.
- [9] C. H. Joshi, Y. Iwasa, "Prediction of current decay and terminal voltages in adiabatic superconducting magnets". *Cryogenics* **29**, p 157-167, 1988.

DISCLAIMER

This document was prepared as an account of work sponsored by the United States Government. While this document is believed to contain correct information, neither the United States Government nor any agency thereof, nor The Regents of the University of California, nor any of their employees, makes any warranty, express or implied, or assumes any legal responsibility for the accuracy, completeness, or usefulness of any information, apparatus, product, or process disclosed, or represents that its use would not infringe privately owned rights. Reference herein to any specific commercial product, process, or service by its trade name, trademark, manufacturer, or otherwise, does not necessarily constitute or imply its endorsement, recommendation, or favoring by the United States Government or any agency thereof, or The Regents of the University of California. The views and opinions of authors expressed herein do not necessarily state or reflect those of the United States Government or any agency thereof, or The Regents of the University of California.