HIGH GRADIENT OPERATION OF 17 GHz RF GUN

Presented by Michael Shapiro

Collaboration with

**W. Brown (now with LLNL), A. Kesar, S. Korbly,
I. Mastovsky, and R. J. Temkin**

MIT Plasma Science and Fusion Center, Cambridge, MA

J. Haimson and B. Mecklenburg

Haimson Research Corporation, Santa Clara, CA

OUTLINE

- ❑ Motivation and Goals
- ❑ 17 GHz 1.5-cell RF Gun Experiment
- ❑ Initial testing of HRC dual feed 2 MeV 17 GHz RF gun
- ❑ Conclusions

17 GHz RF GUN

□ Advantages of Higher Operating Frequency

- Higher Accelerating Gradients can be reached
- Lower Emittance, Higher Brightness beams

□ Goal of the Experiment

- Demonstrate Ultra-High Gradients ($>250\text{MV/m}$)
- Produce an Ultra-High Brightness ($>500 \text{ A}/(\pi\text{mm-mrad})^2$) electron source

RF GUN PRINCIPLE

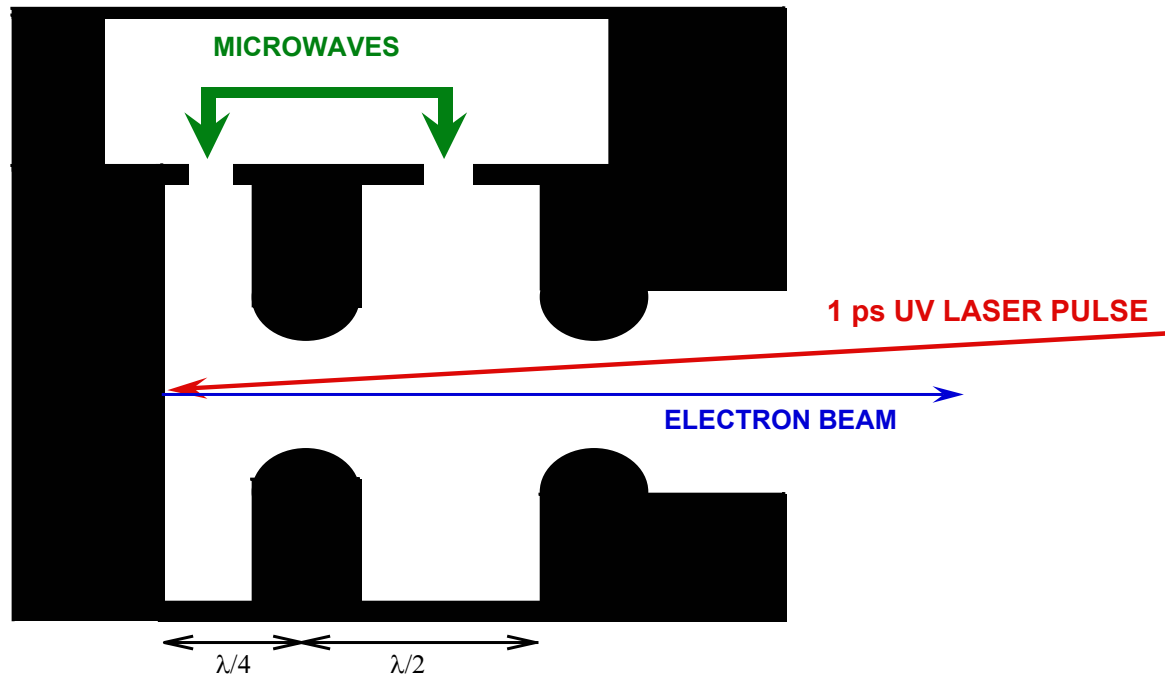

- 1 ½ Cells TM_{010} like cavities
- Acceleration in the RF field stored in the cavity
- Higher Frequency => Higher Gradients, Lower ε_n

17 GHz GUN PHOTO

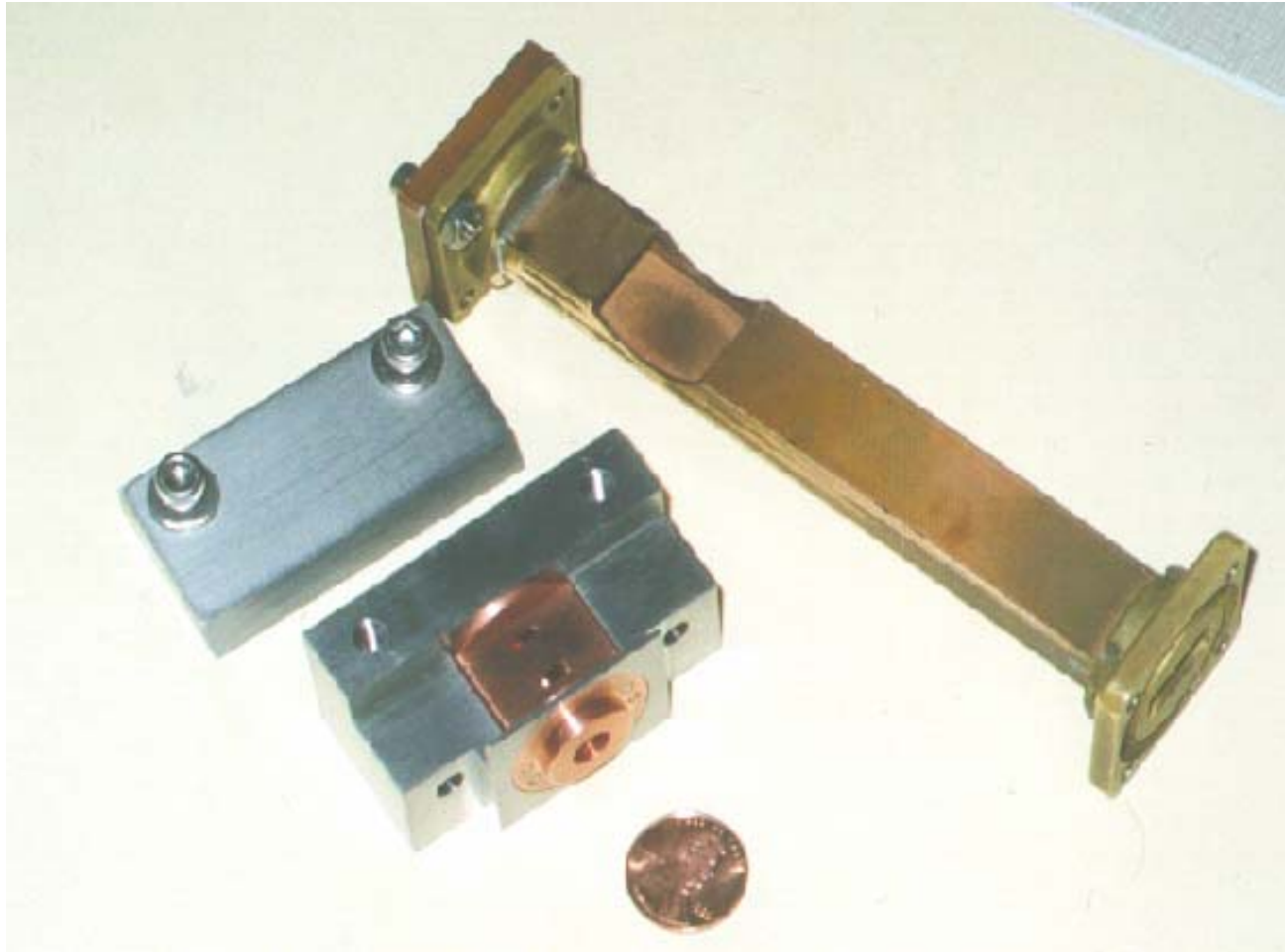

EXPERIMENT SCHEMATIC

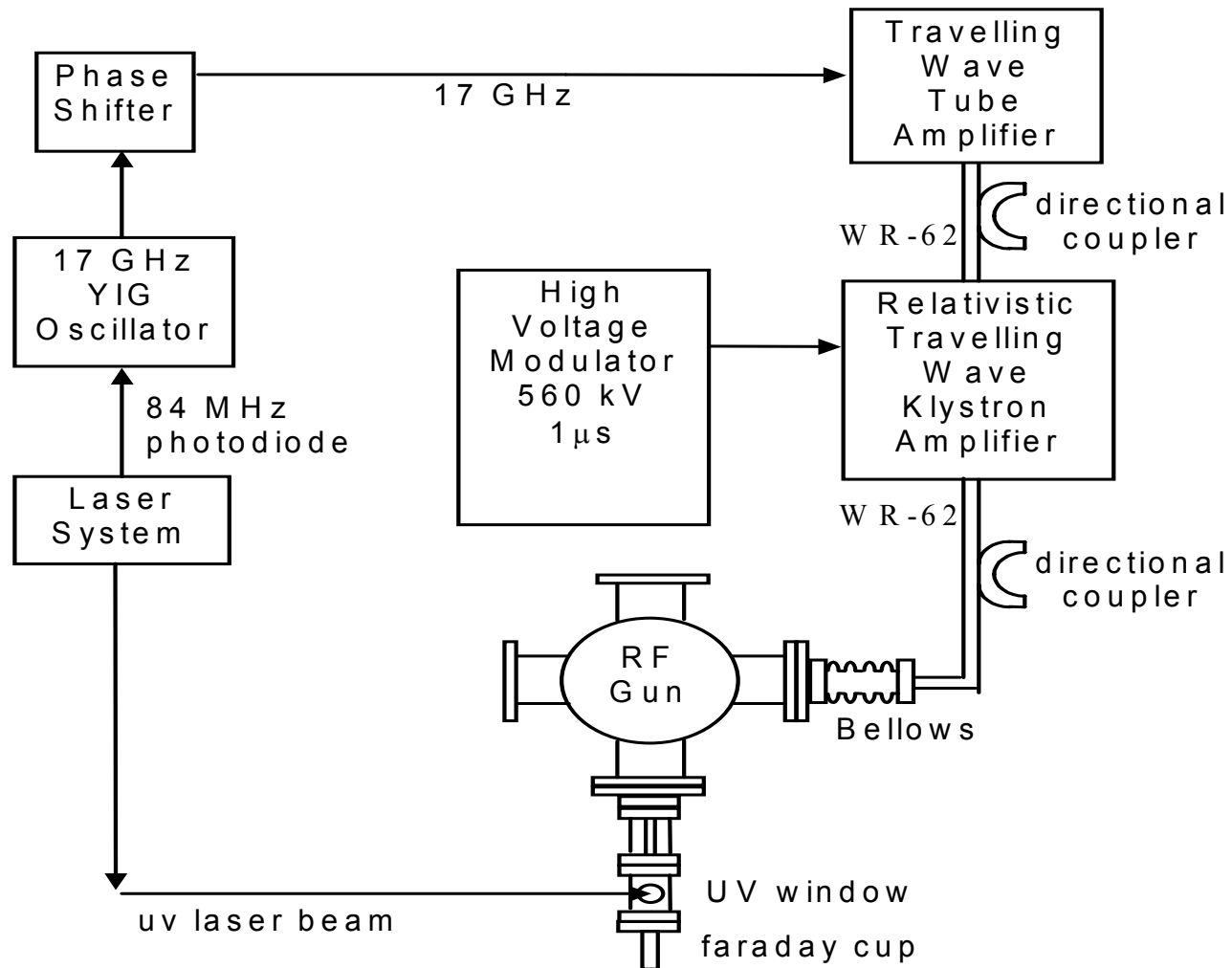

LASER LAB

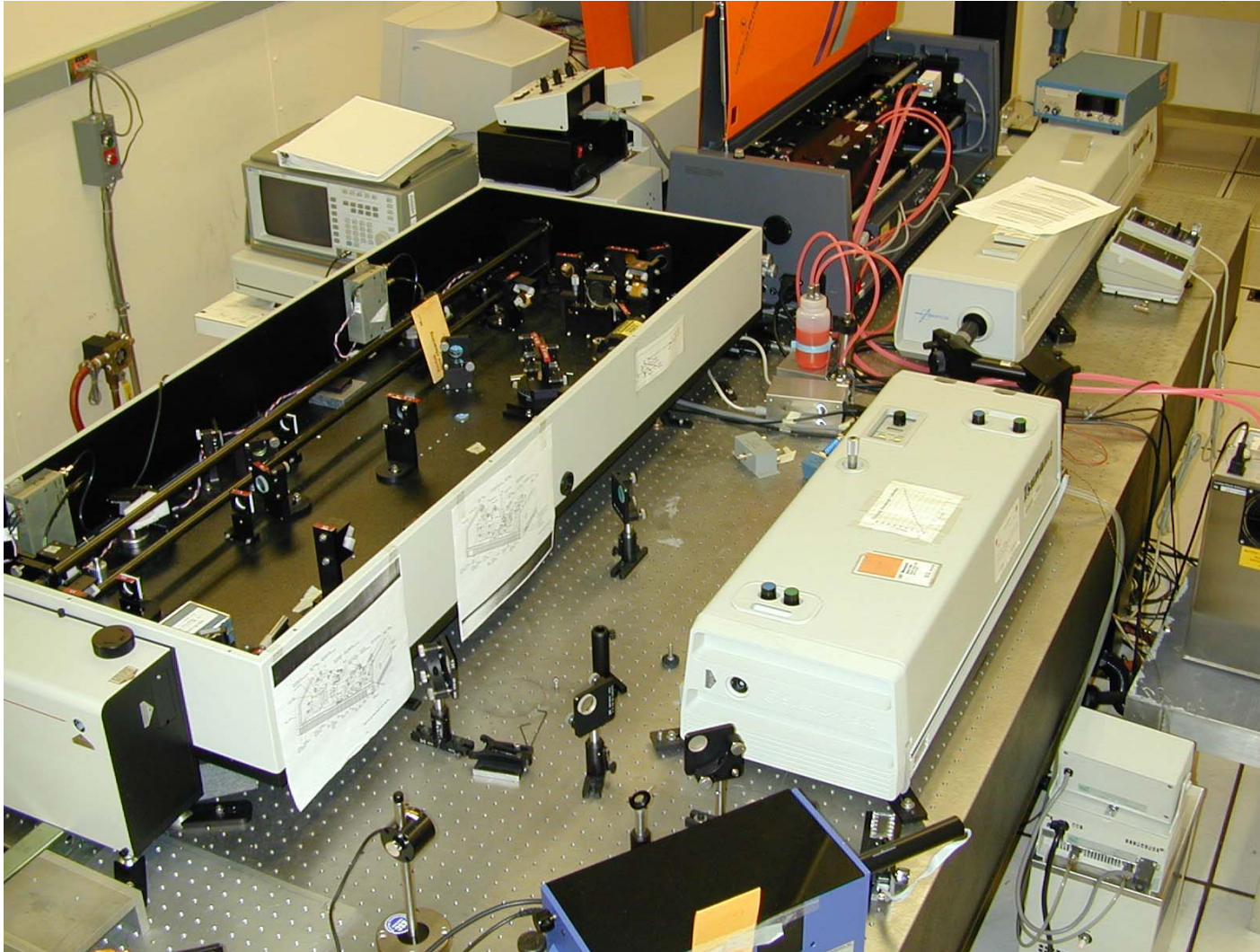

RF GUN LAB PHOTO

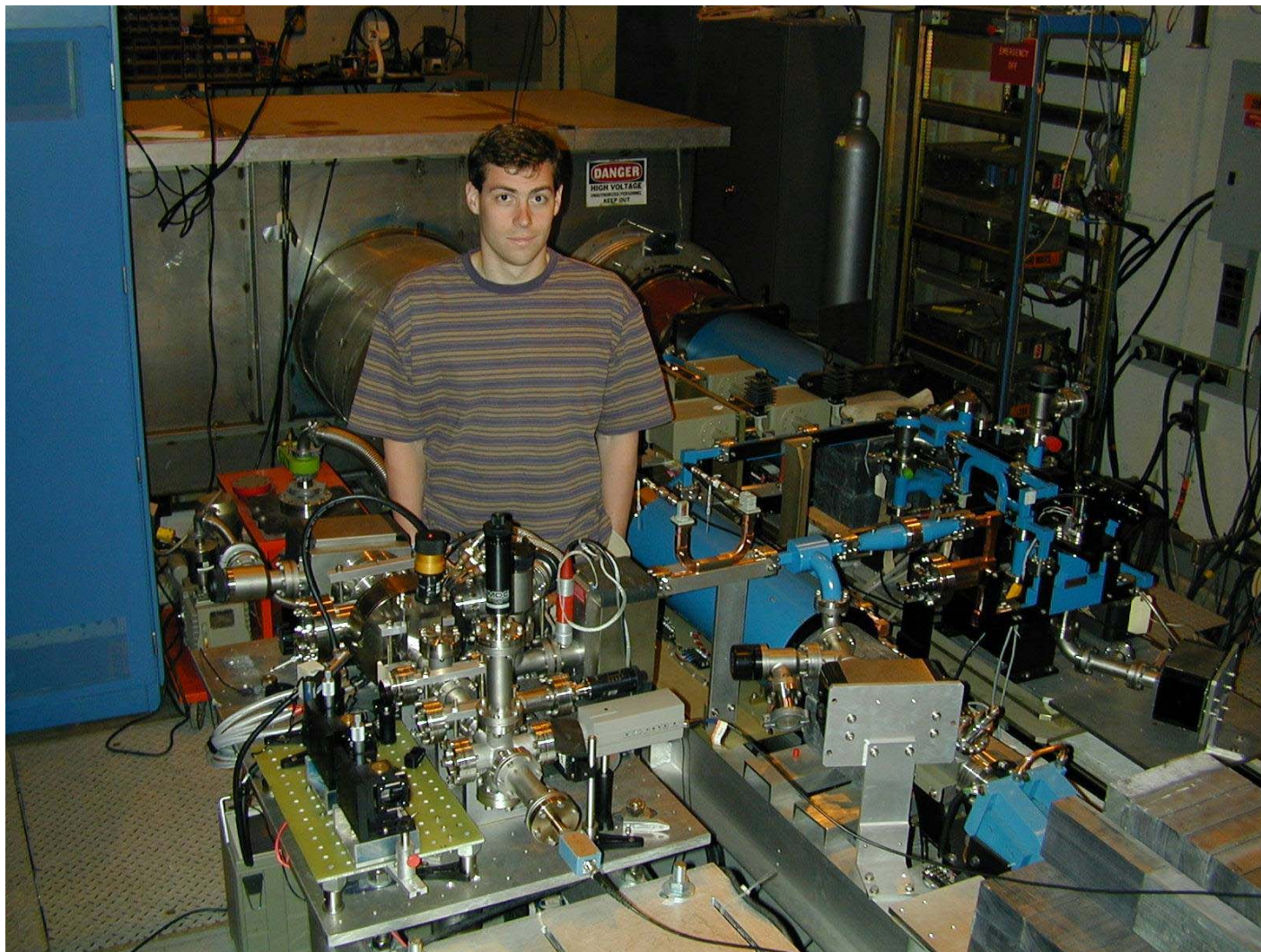

BEAMLINE

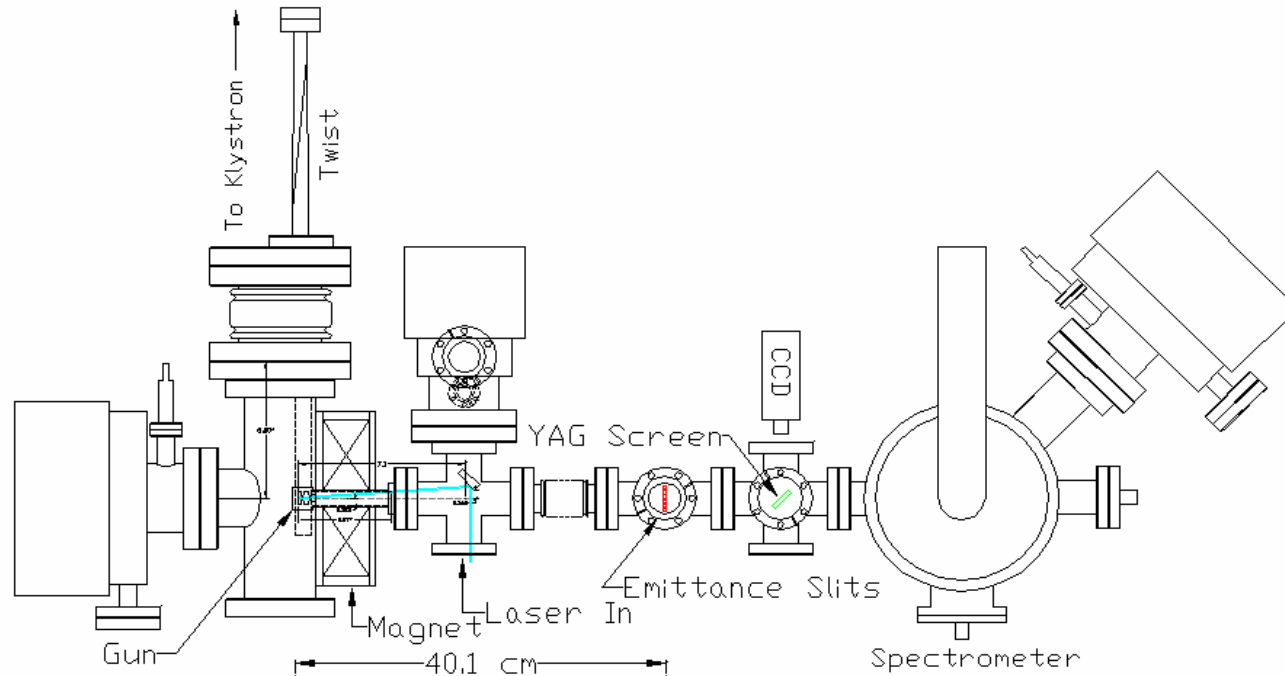

- Emittance Compensation is performed with a 0.5 T solenoid
- Emittance is measured by imaging individual beamlets produced by the slits (50 μm slits in 0.125 mm tantalum foil)
- Beam energy is measured with a magnetic spectrometer

BEAMLINE PHOTO

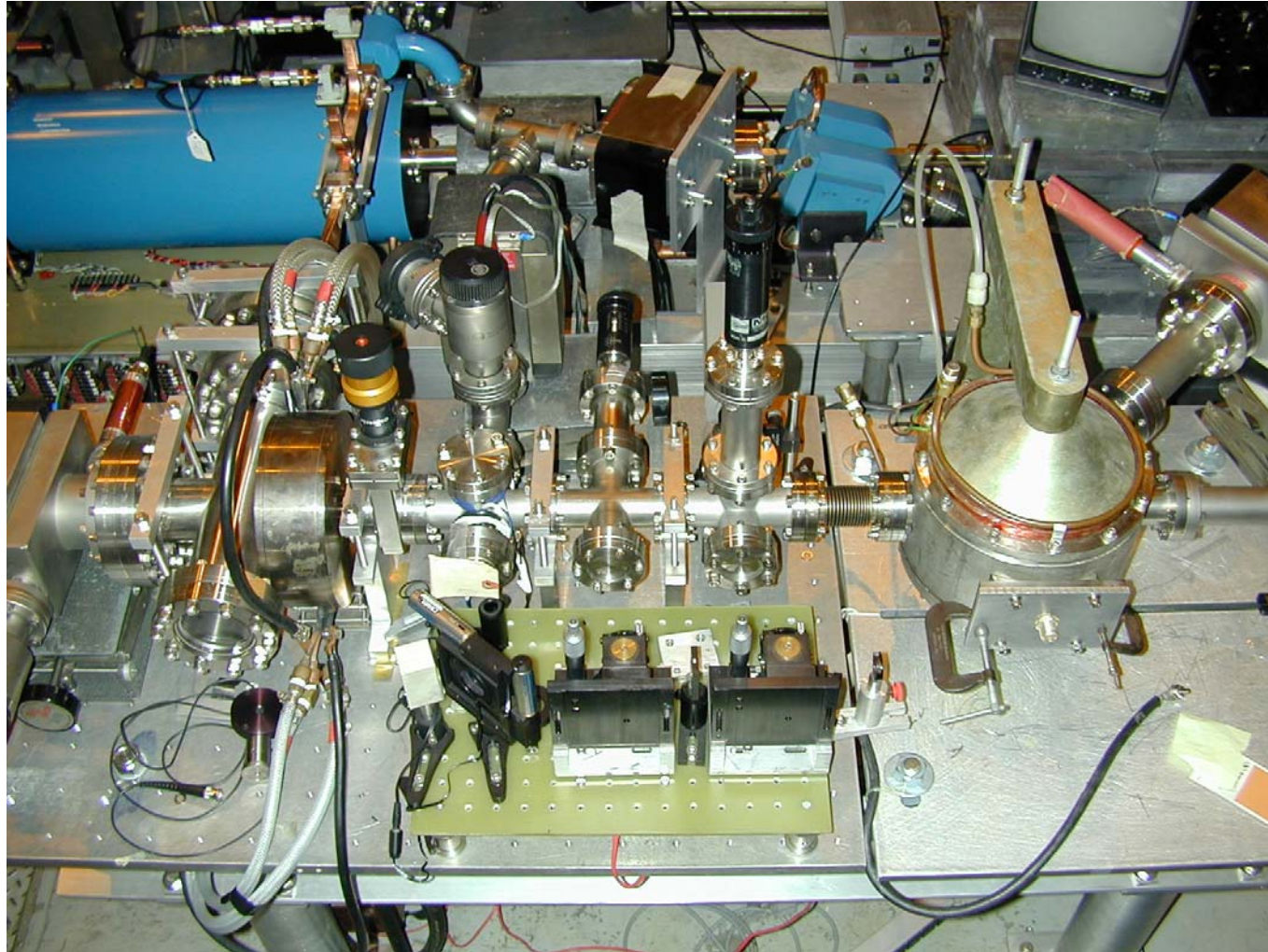

RF GUN COLD TEST

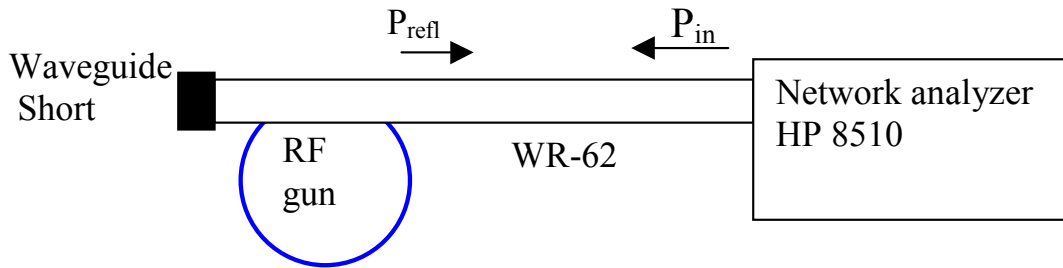

From the measurement of the S_{11} curve, the Q and coupling coefficient, β , of the gun can be determined.

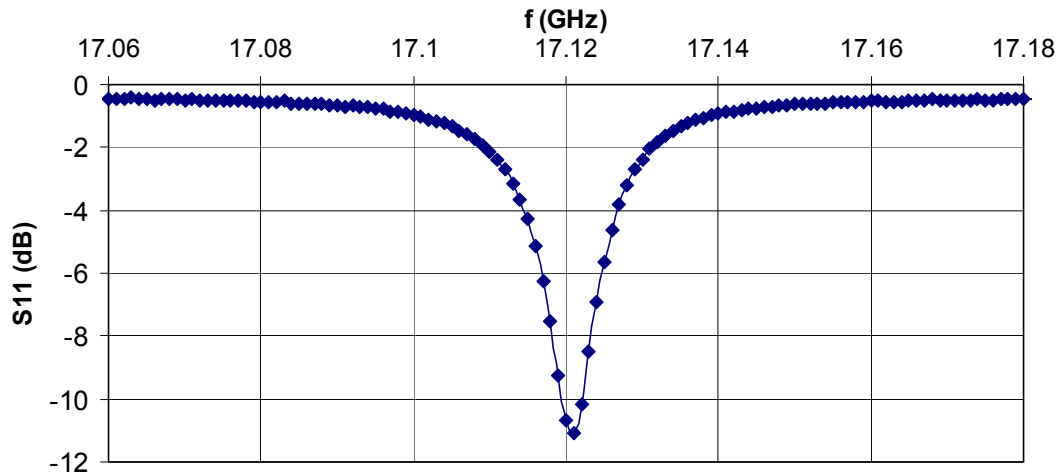

$$f = 17.125 \text{ GHz}$$

$$Q = 1700$$

$$\beta = 0.56$$

BEAD HANG FIELD MEASUREMENT

- Field is measured at the location of the bead by observing a shift in resonant frequency. No hole in cathode needed.

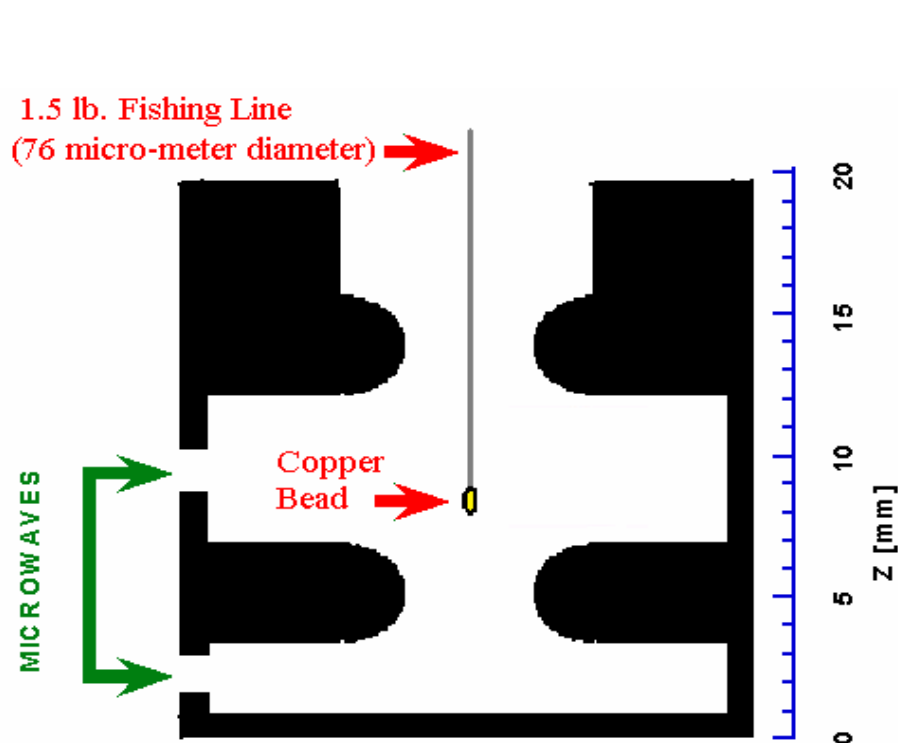

$$\frac{\Delta f}{f_0} = -\frac{1}{W} \left[\begin{array}{l} \varepsilon_0 \left(k_1 |E_{\parallel}|^2 + k_2 |E_{\perp}|^2 \right) \\ - \frac{\mu_0}{2} \left(k_3 |H_{\parallel}|^2 + k_4 |H_{\perp}|^2 \right) \end{array} \right]$$

Near Axis:

$$|E(z)|^2 \propto \frac{(\Delta f(z) - \Delta f_{line}(z))}{\alpha_{bead}}$$

ON AXIS FIELD PROFILE

Cold Test Data

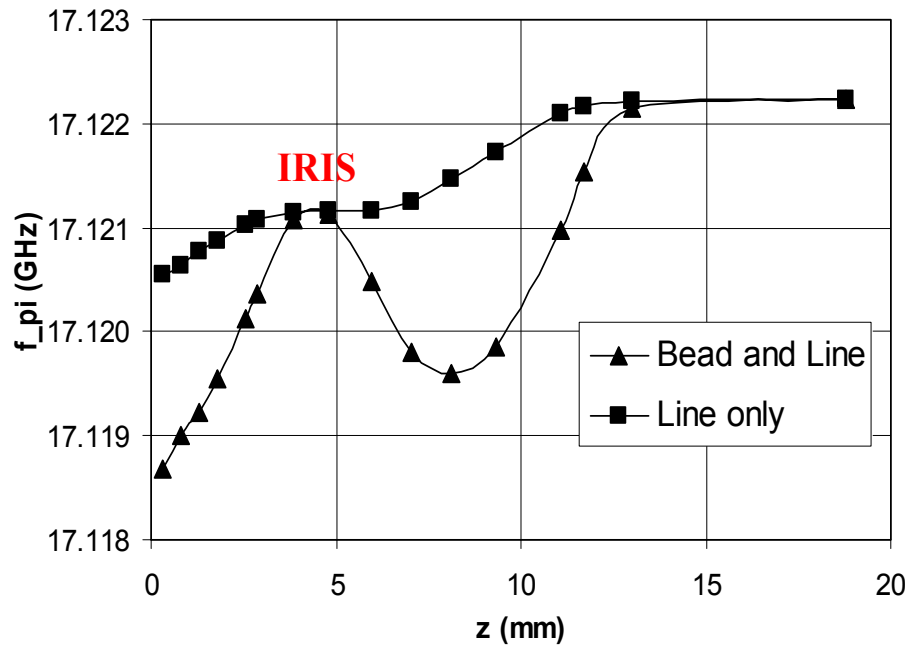

Derived Field Profile

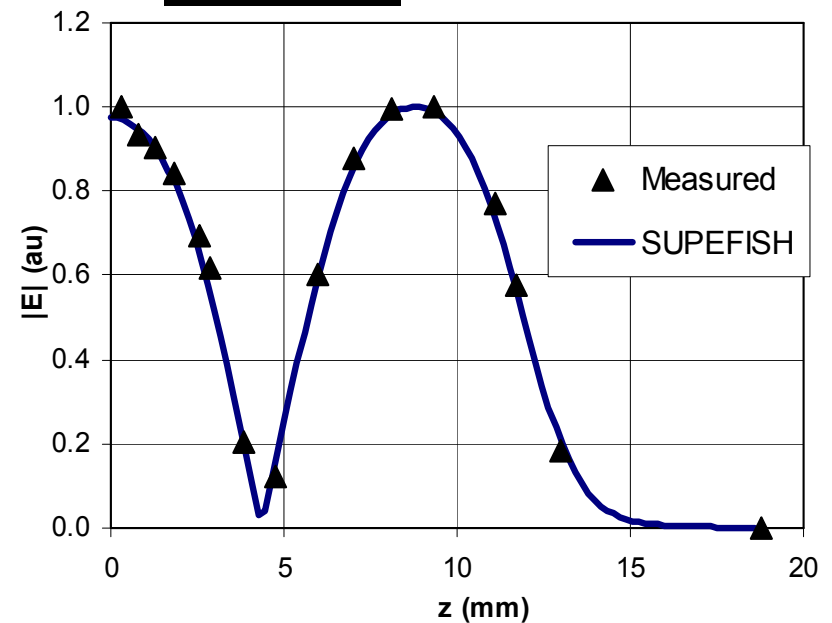

AZIMUTHAL FIELD ASYMMETRY

Coupling hole effects:

- Dipole field asymmetry
- Leads to increased beam emittance, transverse kick to beam.

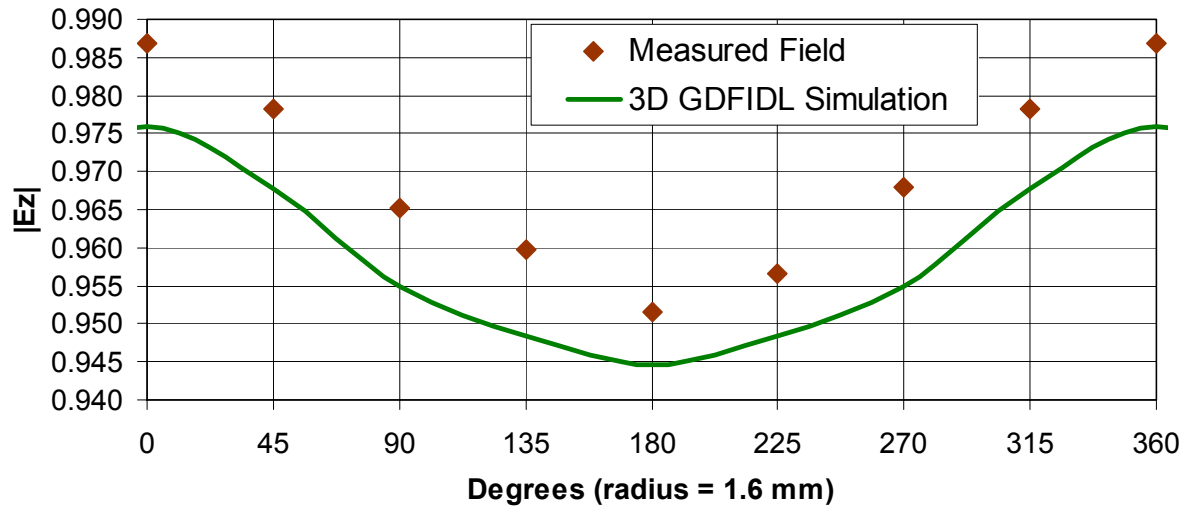
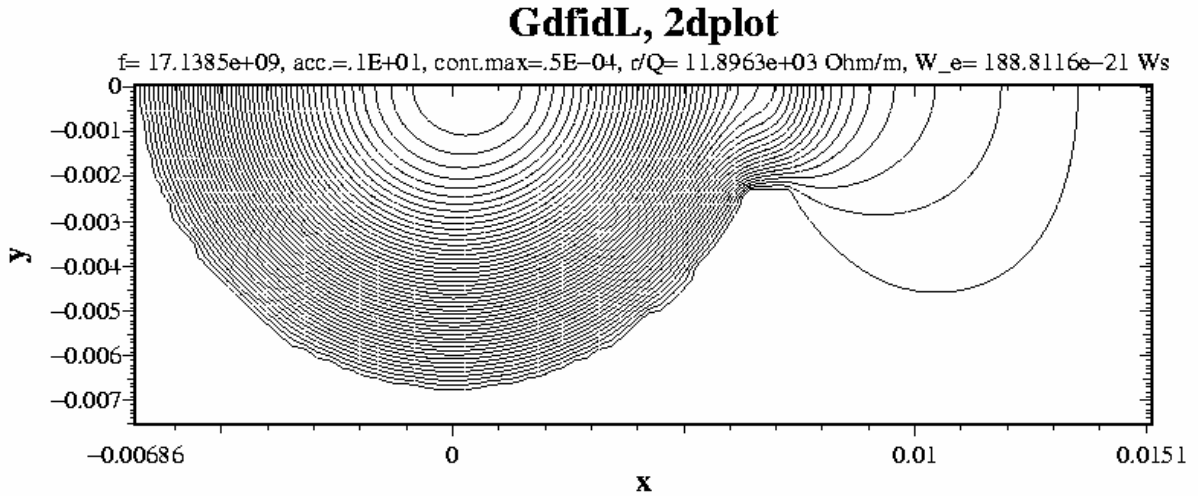

MEASUREMENTS

RF Filling

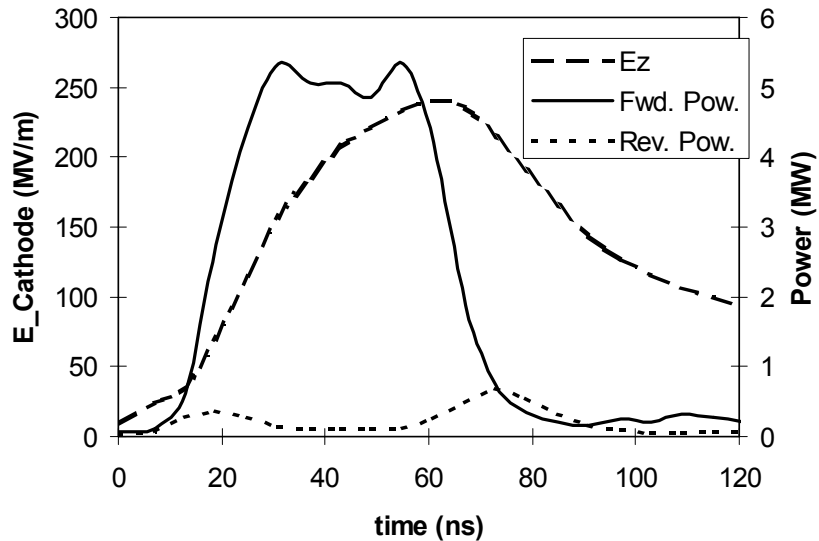

- Up to 200 MV/m peak field achieved (Highest achieved in an RF gun)
- Limited by breakdown.

Faraday Cup

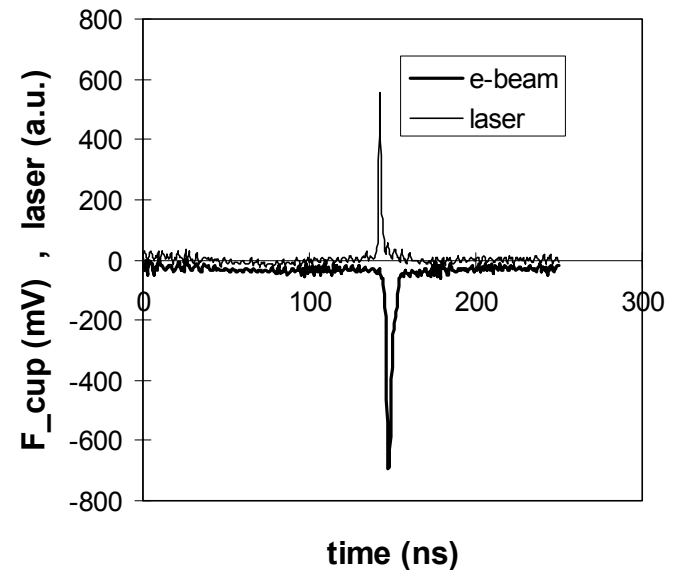

- Up to 0.1 nC of charge detected.

BEAM PROFILE

$B = 0.16 \text{ T}$
 $E \approx 0.8 \text{ MeV}$

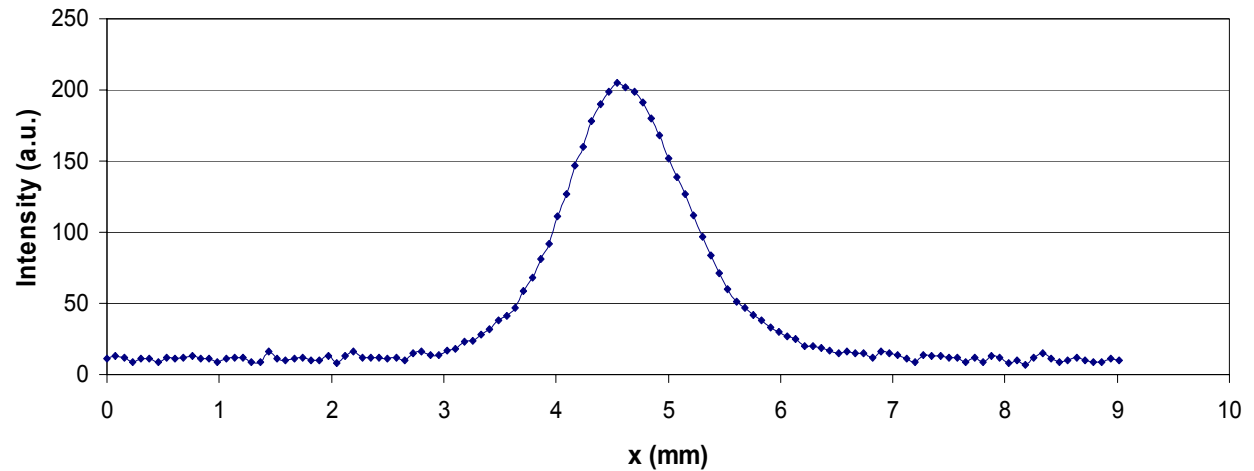
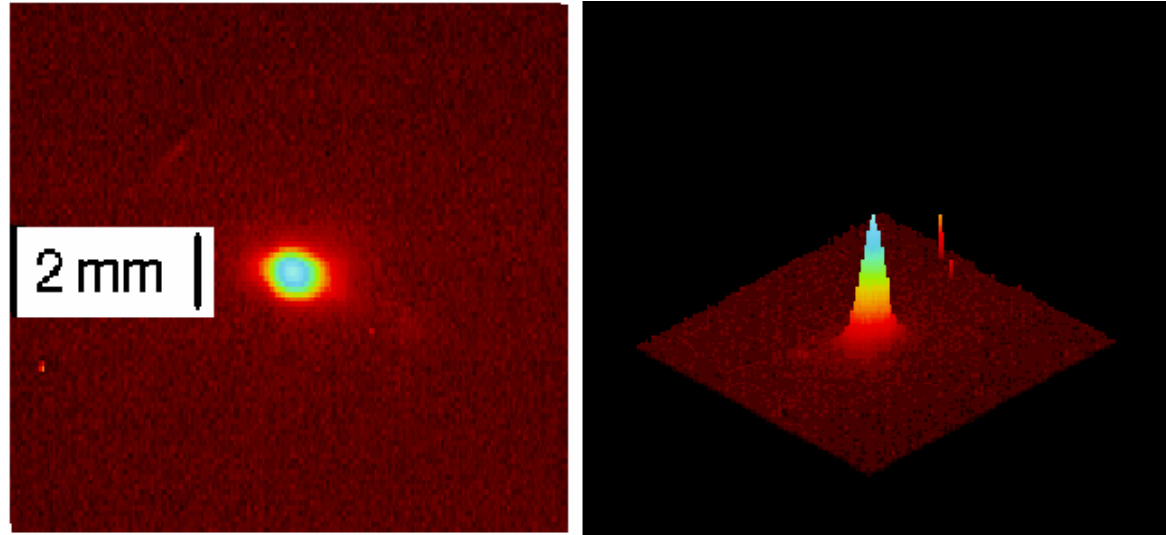

EMITTANCE

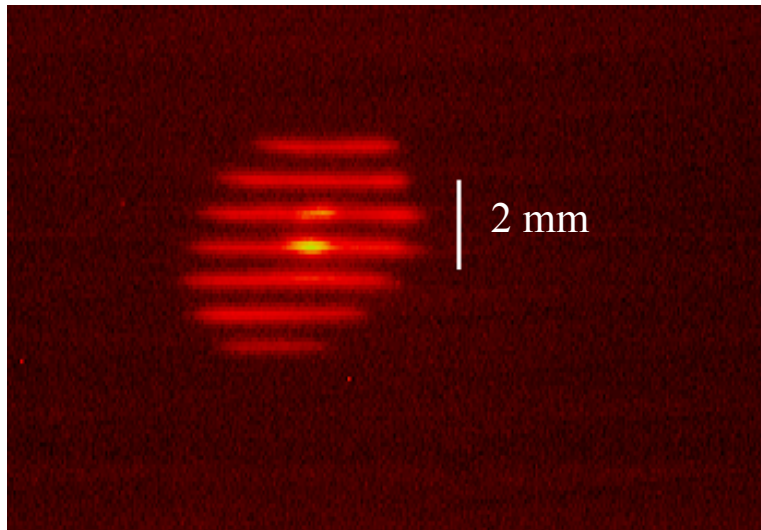

Theory: $Q = 100 \text{ pC}$, $\tau = 1 \text{ ps}$

$E = 2 \text{ MeV}$

$\epsilon_n = 0.5\pi \text{ mm-mrad}$

$B = 800 \text{ A}/(\pi \text{ mm-mrad})^2$

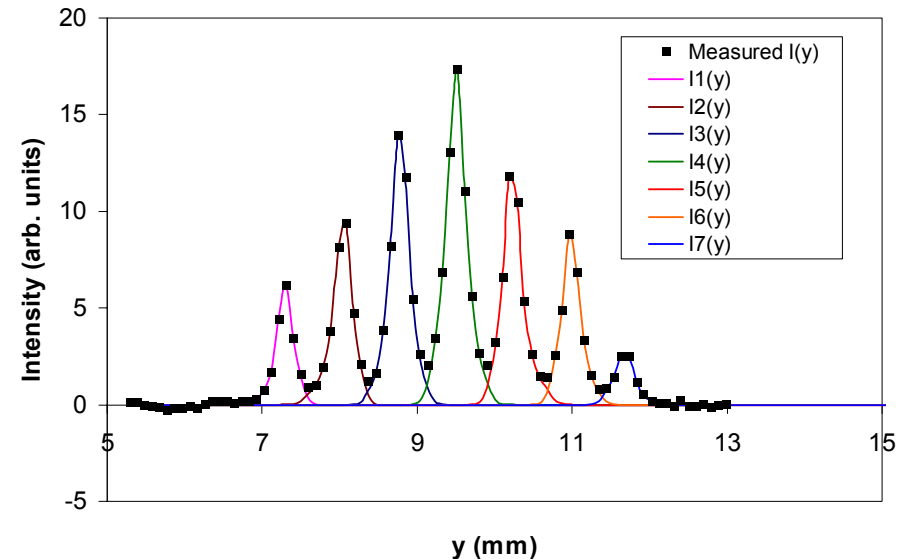

Expt.: $Q \approx 50 \text{ pC}$, $\tau \approx 1 \text{ ps}$

$E = 0.8 \text{ MeV}$

$\epsilon_n = 3\pi \text{ mm-mrad}$ at slits

$\epsilon_n = 1\pi \text{ mm-mrad}$ at gun end
(PARMELA)

$B = 80 \text{ A}/(\pi \text{ mm-mrad})^2$

CONCLUSIONS ON 1.5-CELL RF GUN

- ❑ High Frequency RF guns have the potential to produce record high brightness electron beams

- ❑ 17 GHz 1.5 cell RF gun was designed, built, and tested.
 - Cold tests demonstrated good RF coupling
 - Field profile measurements were performed using a “bead hang” technique, and demonstrated balanced longitudinal field profiles
 - Azimuthal symmetry was measured, and agreed with simulations

- ❑ First operation of an RF gun at 17 GHz was achieved
 - Up to 200 MV/m peak cathode E-field achieved. This is the highest achieved peak field in an RF gun.
 - Emittance $\epsilon_n = 1\pi$ mm-mrad
 - High Beam brightness, up to $80 \text{ A}/(\pi\text{mm-mrad})^2$ produced. Comparable to best results obtained at lower frequency.

**Initial Testing of a Field
Symmetrized Dual Feed 2 MeV
17 GHz RF Gun
built by Haimson Research Corp.**

The HRC RF-Gun

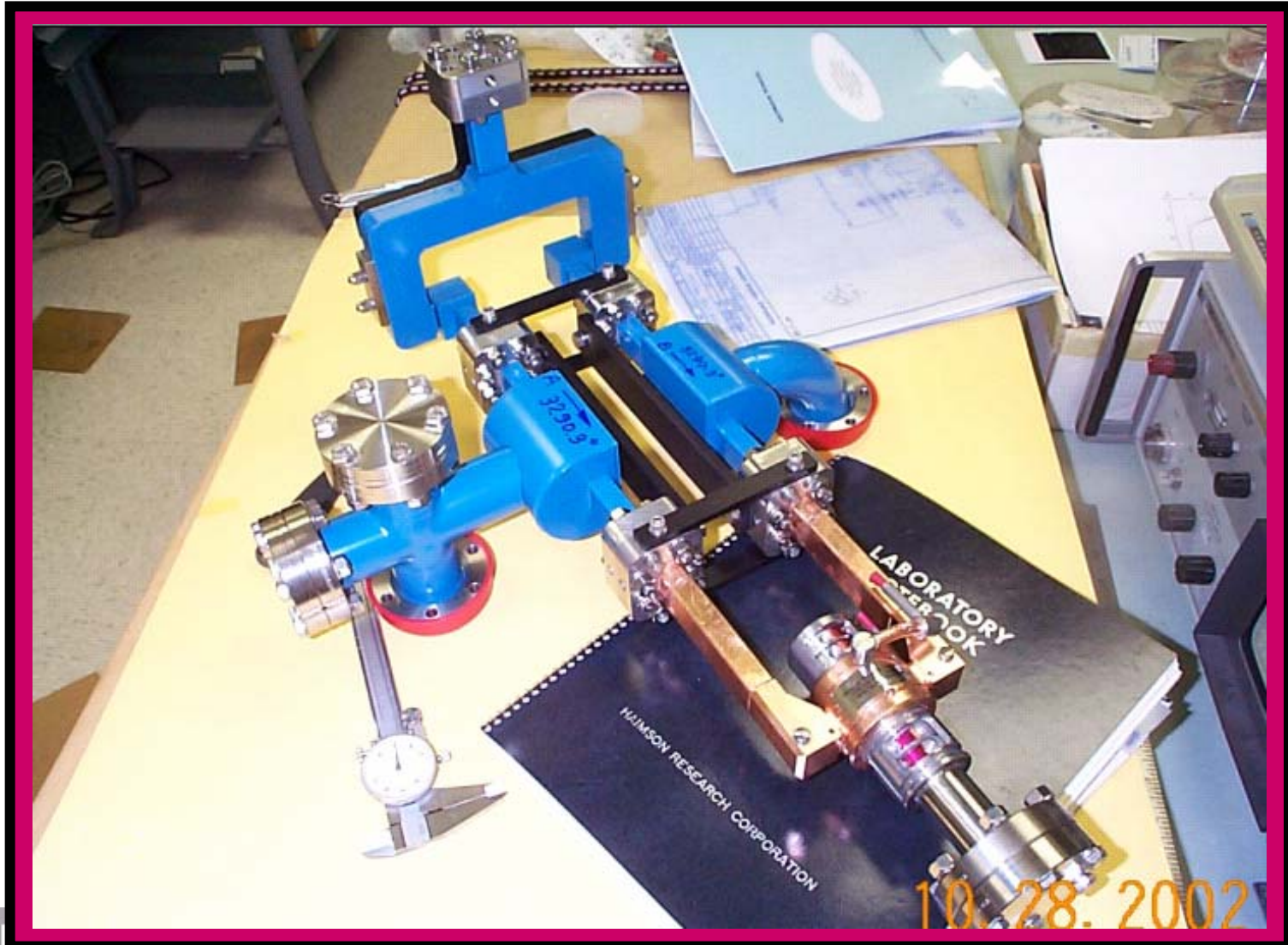

Racetrack Coupling Cavity

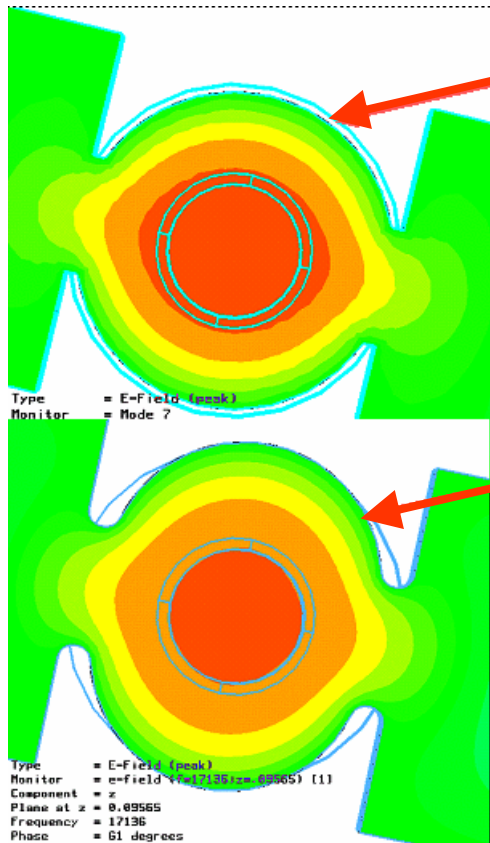

Cylindrical cavity

Racetrack cavity

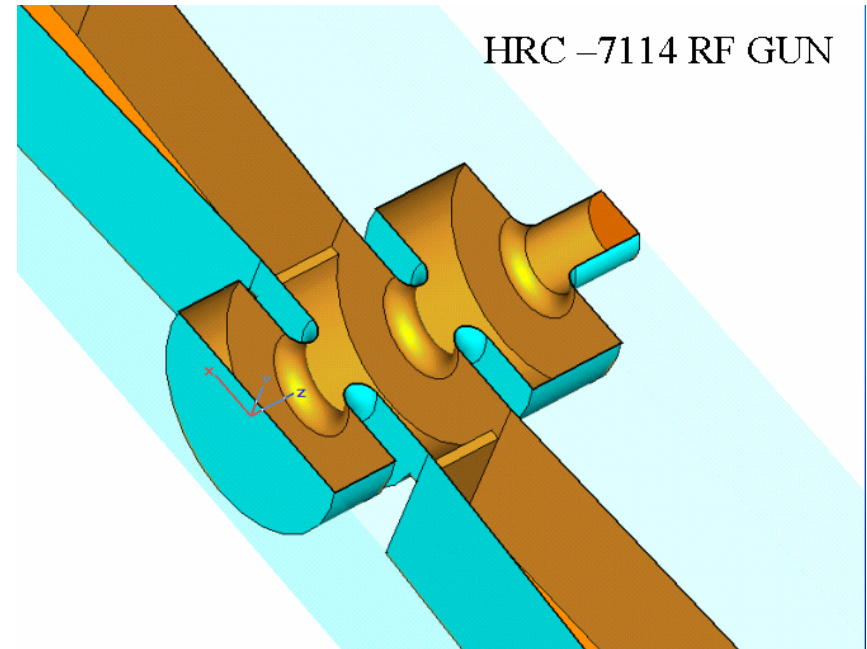

Operating Parameters

Number of cells: 3

Cavity Q: 4600

Resonant frequency: 17.142 GHz

Temperature sensitivity: 280 kHz/°C

RF power: ~1 MW

RF pulse duration: 100 ns

UV Laser energy: ~20 μ J

UV Laser FWHM: 1 ps

Experimental Setup

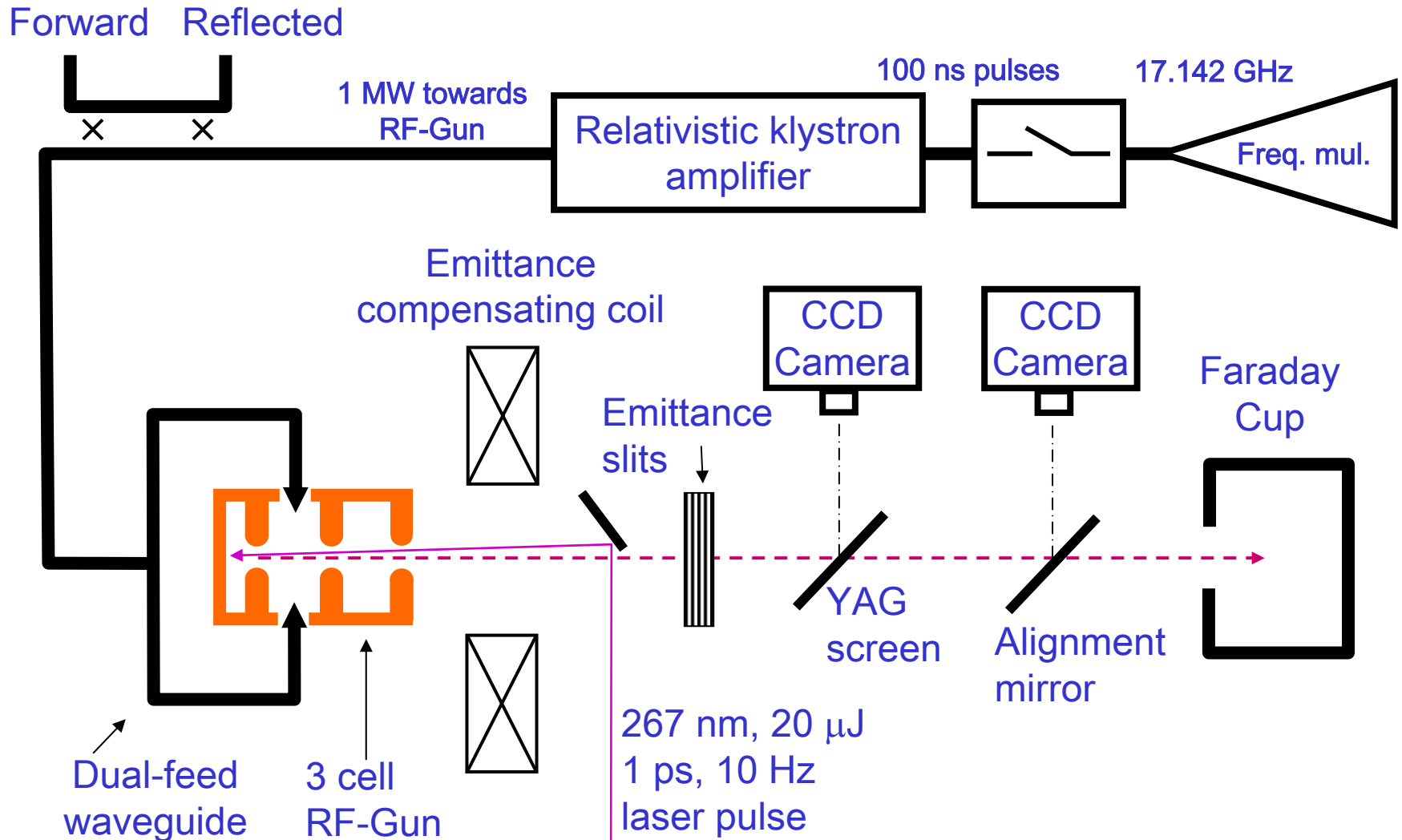

Experimental Setup

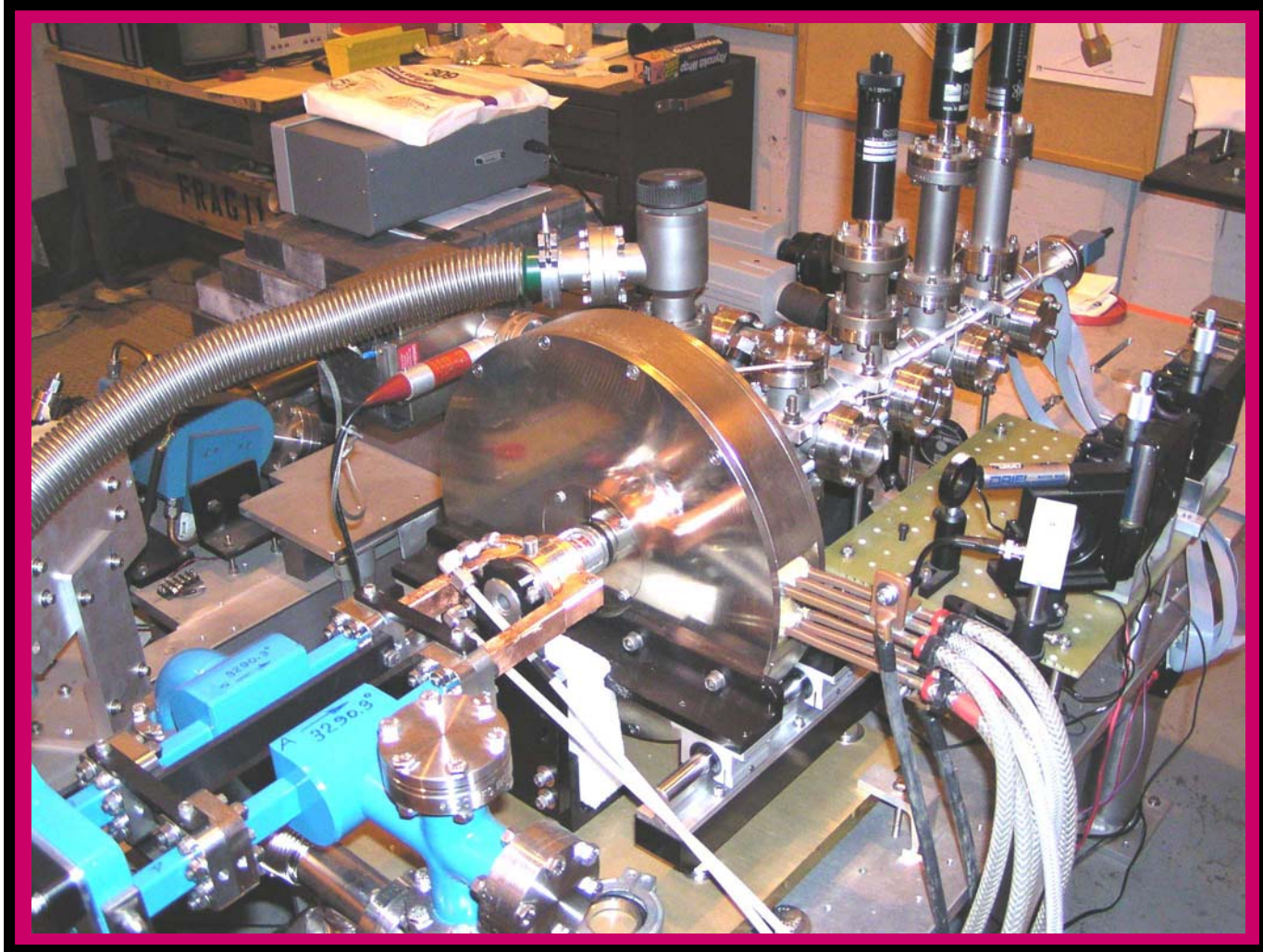

Results and Future Goals

- HRC 17 GHz 2 MeV RF Gun installed at MIT
- RF Gun cold tested and tuned at HRC
- RF Gun processed at MIT using up to 1 MW, 100 ns RF pulses
- Ti: sapphire laser amplifier operation improved
- Will measure charge, emittance, energy
- Optimize operating parameters for maximum brightness and energy